

## MECHANICAL CHARACTERIZATION OF UNIDIRECTIONAL BASALT FIBER EPOXY COMPOSITE

M. H. Lapena<sup>a,\*</sup>, G. Marinucci<sup>a,b</sup>, O. de Carvalho<sup>a</sup>

<sup>a</sup>*Brazilian Navy Technological Center, Materials Technology Dept, Av. Prof. Lineu Prestes, 2268, 05508-900, São Paulo, Brazil*

<sup>b</sup>*Nuclear and Energy Research Institute, IPEN – CNEN/SP, Av. Prof. Lineu Prestes, 2242, 05508-900, São Paulo, Brazil*

\**maurolapena@gmail.com*

**Keywords:** basalt fiber, polymer matrix, mechanical characterization, tensile test.

### Abstract

Basalt fibers present more recent development compared to traditional fibers used in the manufacture of polymer composites, such as glass, aramid and carbon fiber. Some properties, such as strength and modulus, for instance, are located between those offered by E-glass and S-glass fibers. Also show higher working temperature, good chemical and impact resistance, and low outgassing in burning. In addition, their low price – may be lower than that of E-glass fibers – could be another attractive to increase their use. However, there are still few studies in the literature with this reinforcement if compared with glass fiber. In order to design basalt fiber components and perform numerical analysis, there are some input data that need to be determined, such as the elastic properties. The aim of this work is to determine mechanical and elastic properties of basalt/epoxy composites following the ASTM standard. Tensile test was carried out at laminated specimens in longitudinal and transversal fiber directions. The panels were manufactured by a filament winding process and not only the fiber content was obtained for all panels but also the glass transition temperature for the epoxy matrix.

### 1. Introduction

Composite materials are produced to optimize the material properties, including mechanical, chemical and physical, as well as optical and acoustic, electrical and thermal properties. They are manufactured by employing a fiber that exerts the structural function and a polymer matrix that binds and protects the fibers, and also acts as loading distribution element, leading it to the fibers.

Basalt is a volcanic mineral, dark or black. Its rocks are heavy, tenacious and resilient. Its density is about 5% higher than the glass. It's the most abundant crustal rock and the seabed is predominantly composed of basalt. The basalt chemical composition is variable according to the mineral deposit. The weight percentage of the constituent oxides are: SiO<sub>2</sub>, 48.8 to 51; Al<sub>2</sub>O<sub>3</sub>, 14 to 15.6, CaO,  $\approx$  10; MgO, 6.2 to 16; FeO + Fe<sub>2</sub>O<sub>3</sub>, 7.3 to 13.3, TiO<sub>2</sub>, 0.9-1.6, MnO, 0.1 to 0.16; Na<sub>2</sub>O + K<sub>2</sub>O, 1.9-2.2 [1].

The use of basalt fiber (BF) as reinforcement in polymer matrix composites is relatively new compared to popular glass fibers (GF) and carbon fibers. The first trials to produce basalt fiber refer to the year 1923, when the French Paul Dhé was granted a U.S. patent. After World War II, researches were developed in the U.S., Europe and the Soviet Union to get the

fibers extruded and, at this time, the first applications were studied in military and aerospace fields. Only after 1990/92, with the dissolution of Soviet Union, its production technology became public domain, and civilian research begun [2, 3].

The production of fibers was, however, only developed in recent decades. Current technology for producing BF is very similar to that used in E-glass fiber production, but requires less power to be produced [3]. This fact, and the high availability of raw material around the world, justifies the low price of BF compared to GF. The main difference between the BF and GF is the raw material used. GF is produced from various components, while BF is made from the fusion of basalt rock without other additives. The fact of being environmentally friendly makes BF use very attractive and unlike GF, BF does not require additives in their production. The replacement of GF by BF can reduce the risk of environmental pollution with and highly toxic metals and oxides, which are generated in the production of GF [4]. Moreover, BF is an alternative to asbestos fibers, banned for being carcinogenic.

Furthermore, BF has high resistance to acids and solvents, overcoming E-glass fibers and many other mineral and synthetic fibers, nevertheless having less acid resistance than E-glass fibers. Its moisture absorption is less than 0.2% at room temperature and relative humidity of 65%. Also it has excellent wettability with various binders, coatings and matrices. The goal of this work is to obtain mechanical properties of unidirectional laminates in fiber direction (0°) and transverse direction (90°), as well as composites volume fractions and polymer matrix glass transition temperature.

## **2. Materials and Method**

### *2.1. Basalt Fiber-properties and application*

BF is highly competitive with GF, mainly in comparison to mechanical properties, besides to overcome them in certain properties – in particular as water resistance and chemical stability. In various forms of presentation, whether as twisted and non-twisted filaments, yarns, fabrics or mats, BF represent a promising alternative as a reinforcement element for composite materials. Furthermore, it has been a solution for some specific problems, for instance, for manufacturing composites in which the design requires different loads and deformations in many directions; in that case, producing a hybrid composite with GF (high resistance) and carbon fibers (high strength and high modulus), that can meet all the necessary requirements [5].

BF is applicable in many areas due to its wide range of properties. It exhibits excellent resistance to alkalis, similar to GF, at a much lower cost than carbon and aramid fibers. Its thermal properties make it an excellent substitute for high temperature resistant fibers (carbon fibers) and is commonly used in the manufacture of heat shields, heat insulating barriers and articles for fire protection – in addition to working temperature markedly higher than GF, from -260 °C to 700 °C, against -60 °C to 250 °C for glass [3].

The vibration damping of BF is much higher than of GF, which made them suitable for applications under high loads and acoustic vibrations, such as structures where such conditions exist, for example, in the aerospace and marine industry [3]. Its high water resistance also explains the wide application in the marine industry, as in the production of boat hulls. Due to its good electrical insulation properties (10 times greater than glass) [3], BF

is used in printed circuit boards, extra-thin insulation for electrical cables and underground pipelines. Regarding the mechanical properties of the BF in comparison to that of glass fiber and carbon fiber, as shown in Table 1, elastic modulus and tensile strength of BF exceeds the GF in around 11% (resistance) and 15% (modulus).

	Basalt fiber [6]	E-glass fiber [7]	Carbon fiber [7]
<b>Tensile strength [MPa]</b>	2800-4800	3450	3500
<b>Elastic modulus [GPa]</b>	89	72,4	240
<b>Elongation at break [%]</b>	3,1	4,7	1,25
<b>Density [g/cm<sup>3</sup>]</b>	2,8	2,6	1,75

**Table 1.** Comparison of fibers properties.

One of many applications for BF is in the manufacturing of compressed natural gas cylinders. Kamenny Vek performed tests in order to compare the mechanical properties of cylinders made of epoxy matrix composite reinforced with basalt fiber (BF), E-glass fiber (E-GF) or carbon fiber (CF), using the filament winding technique. The cylinder could be manufactured using a metallic mandrel, which is reinforced in its outer surface by winding BF rovings wet with epoxy resin, as illustrated in Figure 1 [6].

## 2.2. Filament Winding Technique

The best use of fiber properties applied as continuous reinforcement occurs when they are requested in its longitudinal direction. Filament winding technique stands out as the manufacturing process that makes better use of this advantage. Components manufactured by this process aim to achieve one of the highest strength-to-weight ratios between materials used for structural applications. However, to ensure this result, it is necessary that the fiber direction is in the principal stresses direction, and at the same time to use matrix reinforcement fraction proportional to these stresses magnitude.

Filament winding technique consists in the deposition of continuous filaments impregnated with resin onto a mold or rotary cylinder, using a computer numerical control (CNC). The basalt filament bobbins (rovings) are placed in a holder with tension control of filament. The filaments released from the system pass through a heated bath of matrix (resin-curing agent-accelerator) equipped with a temperature control. The mold remains in a horizontal position and rotates pulling the filament, while the car has longitudinal movement parallel to the mandrel axis. The winding parameters such as filament tension, die angular velocity and longitudinal velocity of the car are controlled by the CNC. The coordinate movement of these two axis establishes the fiber deposition angles over the mandrel. An illustration of a filament winding machine with two freedom degrees is shown in Figure 2. It is recommended that the production environment has controlled temperature and humidity.



**Figure 1.** Compressed natural gas cylinder reinforced with epoxy/BF and BF roving [8].

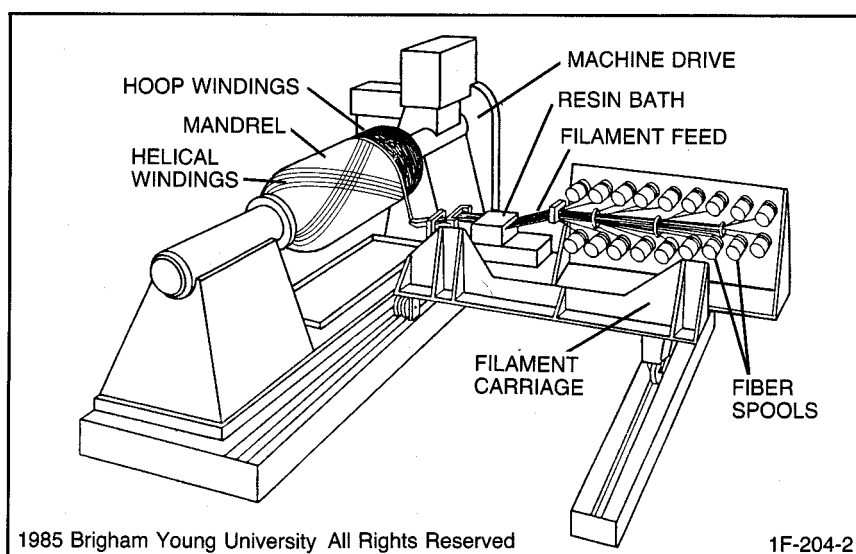

**Figure 2.** Filament winding machine [9].

Filament winding is one of the most efficient methods to manufacture cylindrical structures. Pipes, tanks, gas cylinders, cylinder shells, rockets and missiles are among structures fabricated by this process. Other features from this process are the possibility of obtaining high fiber volume fractions (60-75%), possibility of large parts fabrication, producing smooth inside structures and still to require little manual labor, with great possibility of automation. Some limitations of the process are associated with relatively high investment, shape limitation of parts (without dimples) and require skilled labor [10].

### 2.3. Method

A unidirectional basalt/epoxy composite was manufactured wound the fiber onto a spindle-shaped flat rectangular metallic mandrel with two working faces, that was internally heated up

to 70°C. BF was supplied by Kammeny Vek in continuous filament with a linear density of 1200 tex, made from fibers of 13 µm diameter, with silane agent sizing compatible with epoxy and phenolic resins. The mandrel was coated with an impermeable adhesive film to ensure efficient composite demolding, as can be seen in figure 3.

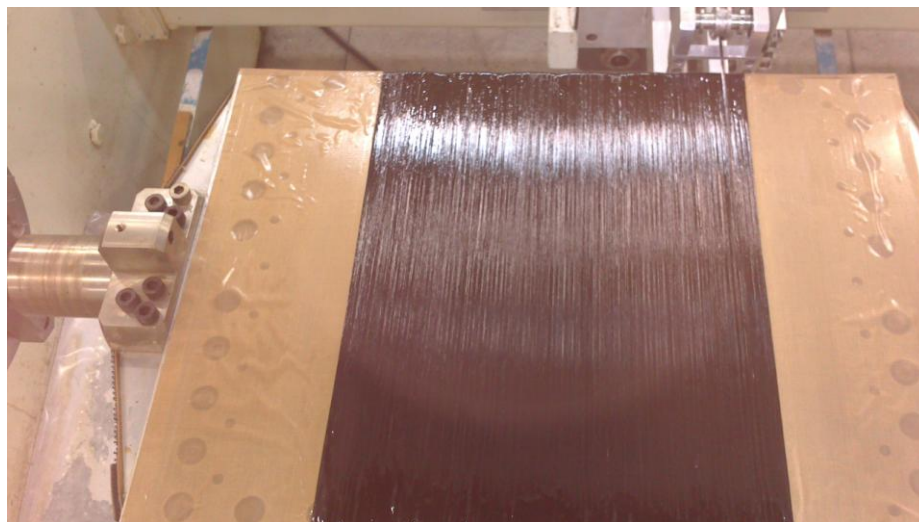

**Figure 3.** A basalt fiber panel manufactured by a filament winding technique.

After the process the mold is pressed in both sides with flat and polished steel plates (caul plates), as shown in Figure 4, provided with end stops fixed by bolts at their ends. In order to produce panels with the desired thickness, the end stops determine the thickness of the panels, which were produced with 1 and 2 mm in accordance ASTM 3039. The set mold-press panel was taken to oven for a curing cycle of 11h, reaching a maximum temperature of 130°C, with slow cooling in the air at oven.

The 1 mm thickness panels were laid with  $[0_4]_T$ , and the 2 mm ones  $[90_8]_T$ . Specimens were cut using a diamond saw and the final dimension were 250 x 15 x 1 mm for 0° and of 175 x 25 x 2 for 90°. A sketch, on Figure 5, shows the 90° specimens on the panel where they were cut off. Both, mandrel and resin bath were kept at the same temperature during the winding process.



**Figure 4.** The set mold-press panels.

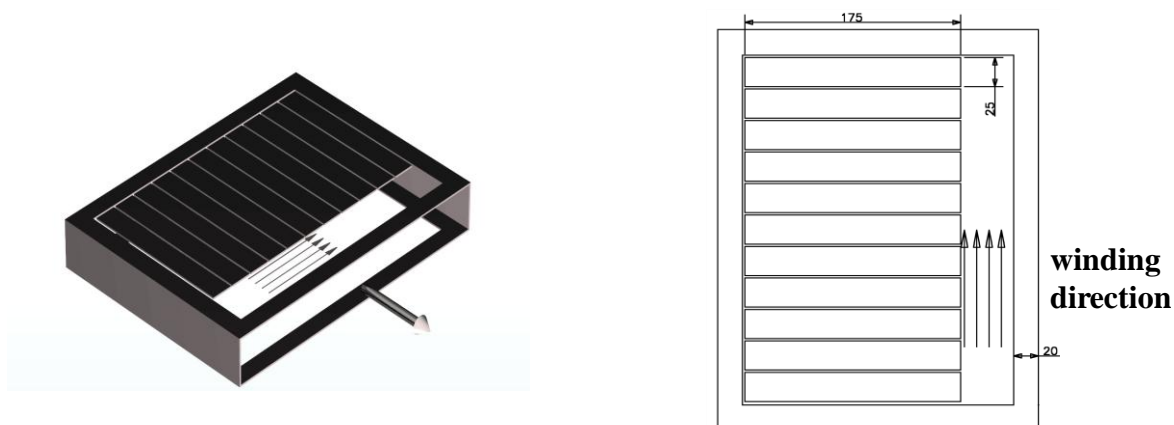

Figure 5. Basalt/epoxy panel sketch and transversal cutting direction of the specimens.

### 3. Results

All tensile tests are performed following ASTM D3039/D3039M standard [11]. The tables 2 and 3 show the properties respectively in longitudinal and transversal directions, with the curves of these tests in figures 6 and 7. The terminology in the last column of the tables 2 and 3, in accordance ASTM 3039, defines the mode and location of failure of the specimen. For instance, XGM (specimen 1 of longitudinal direction test in Table 2) means eXplosive, Gage, Middle, representing that the failure was as a sorceress's broom and the failure happened in the gage length of the specimen, in the middle position.

Specimen	Load (N)	Ultimate Tensile Stress (MPa)	Modulus of Elasticity (MPa)	Poisson Ratio (chord 0.10%-0.60%)	Strain (%)	Failure Mode
01	24213	1663	50	0.222	3.48	XGM
02	23640	1640	48	0.209	3.36	MGM
03	21803	1518	48	0.173	3.07	SGM
04	22572	1568	50	0.293	-	MGM
05	22000	1546	52	0.290	-	XGM
	22846	1587	50	0.237		-
	1046	62	1.5	0.05		-

Table 2. Experimental properties of basalt/epoxy composites specimens in the longitudinal direction (0°).

Specimen	Load (N)	Ultimate Tensile Stress (MPa)	Modulus of Elasticity (MPa)	Poisson Ratio (chord 0.10%-0.25%)	Strain (%)	Failure Mode
01	2137	45	23	0.447	0.31	LAT
02	2026	42	23	0.409	0.30	LAT
03	2106	44	27	0.736	0.26	LAT
04	2796	58	16	-	0.36	LAT
05	2636	55	15	-	0.35	LAT
	2340	49	21	-	0.32	-
	350	7	5	-	0.04	-

Table 3. Experimental properties of basalt/epoxy composites specimens in the transversal direction 90°.

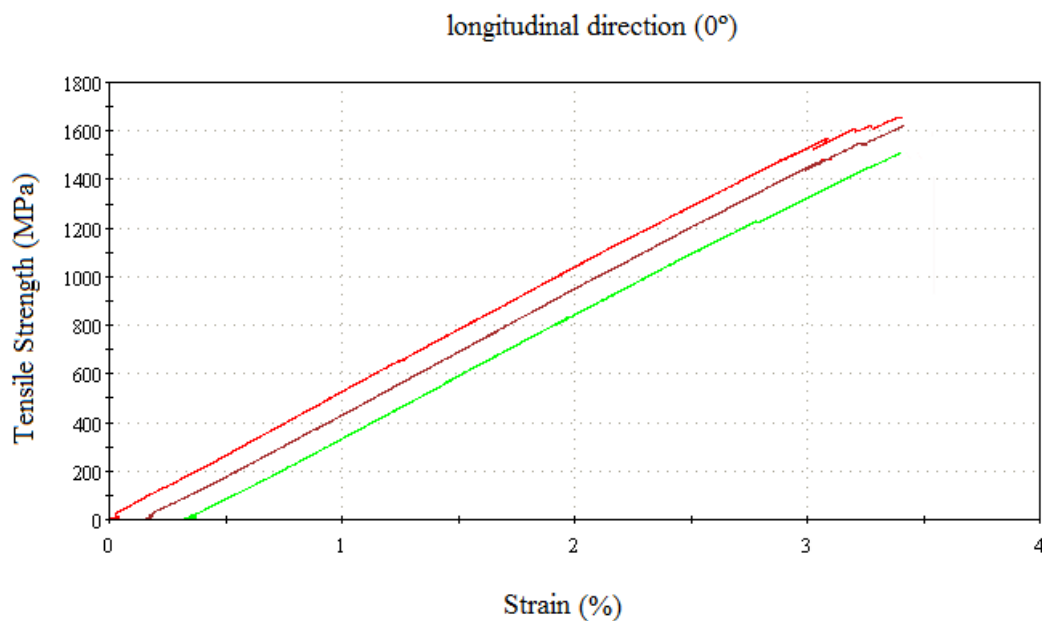

**Figure 6.** Tensile strength versus strain curve for basalt/epoxy composite specimens 1, 2 and 3 in the longitudinal direction ( $0^\circ$ ).

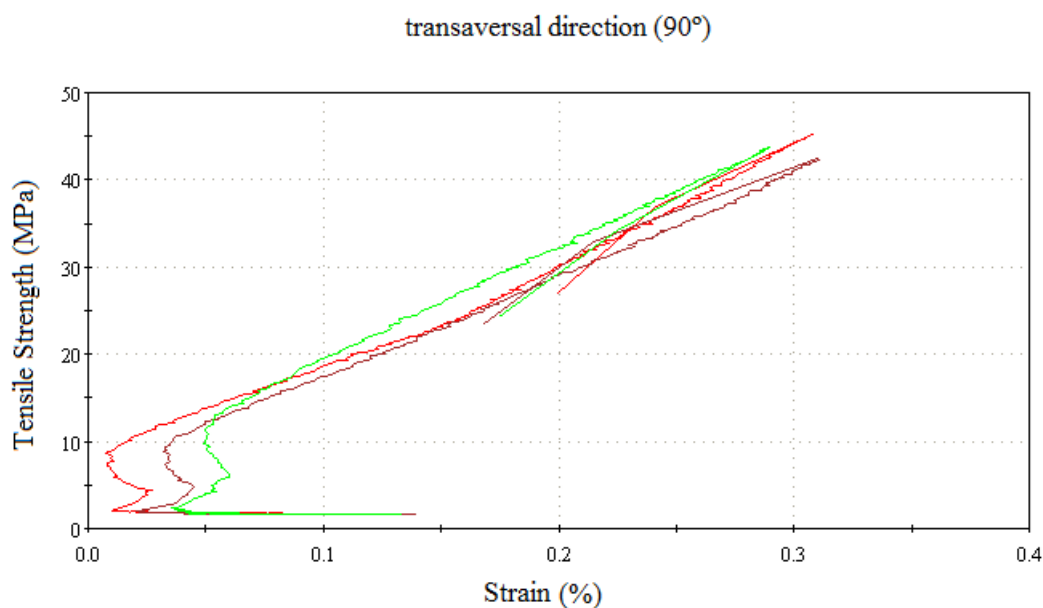

**Figure 7.** Tensile strength versus strain curve for basalt/epoxy composite specimens 1, 2 and 3 in the transversal direction ( $90^\circ$ ).

To obtain the Poisson ratio for the specimens, the strains in the longitudinal and in the transversal directions were determined by means of an optical extensometer (specimens 1, 2 and 3) and a bidirectional extensometer (specimens 4 and 5) for both longitudinal ( $0^\circ$ ) and transversal ( $90^\circ$ ) direction.

The glass transition temperature of the epoxy matrix was  $121^\circ\text{C}$ .

#### 4. Conclusions

Comparing the average values from Tables 2 and 3 with those presented by Leitão, 2007 [12], considering glass fiber-E, as shown in Table 4, the basalt/epoxy composite shows a tensile stress 15% higher than glass fiber-E/epoxy composite in the longitudinal direction (0°) and the same modulus of elasticity. In transversal direction, tensile stress of the basalt fiber/epoxy composite is 22% higher and the modulus of elasticity 23% also higher than glass fiber-E/epoxy composite.

basalt/epoxy composites fiber fraction 60-65%	Ultimate Tensile Stress (MPa)	Modulus of Elasticity (MPa)	glass fiber-E/epoxy composites fiber fraction 60-65%	Ultimate Tensile Stress (MPa)	Modulus of Elasticity (MPa)
0°	1587±62	50±1.5	0°	1369±35	50±1
90°	49±7	21±5	90°	40±3	17±1

**Table 4.** Experimental properties of basalt/epoxy composites compared with glass fiber-E/epoxy specimens.

#### 5. Acknowledgments

The authors thank to Fundação de Amparo à Pesquisa do Estado de São Paulo - FAPESP for financial support, according to the process 2014/05172-7 and to Brazilian Navy Technological Center in São Paulo for the technical support.

#### References

- [1] S. E. Artemenko. Polymer composite materials made from carbon, basalt and glass fibres. Structure and properties. *Fibre Chemistry*, v(35):226-229, n°.3, 2003.
- [2] C. Colombo, L. Vergani and M. Burman. Static and fatigue characterization of new basalt fibre reinforced composites. *Composite Structures*, v.94, p. 1165-1174, 2012.
- [3] P. Fazio. Basalt fibra: from earth an ancient material for innovative and modern application. *Energia, Ambiente e Innovazione*, 3/2011.
- [4] R. Parnas, M. Shaw and Q. Liu. Basalt Fiber Reinforced Polymer Composites. *The New England Transportation Consortium*, 2007.
- [5] N. M. Chikhradze, L. A. Japaridze and G. S. Abashidze. Properties of Basalt Plastics and of Composites Reinforced by Hybrid Fibers in Operating Conditions. In InTech, Ning Hu, *Composites and Their Applications*, 2012.
- [6] [www.build-on-prince/basalt-fiber.html](http://www.build-on-prince/basalt-fiber.html) [accessed 14.03.2014].
- [7] C. Colombo, L. Vergani and M. Burman. Static and fatigue characterization of new basalt fibre reinforced composites. *Composite Structures*, v.94, p. 1165-1174, 2012. In: C. J. Burgoyne, N. Taranu, K. Pilakoutas, A. Serbescu, V. Tamuzs, A. Weber. *FRP reinforcement in RC structures*. Stuttgart: Sprint Digital, Druck Editor, 2007.
- [8] Kammeny Vek datasheet. Available from: [www.basfiber.com](http://www.basfiber.com) [accessed 20.01.14].
- [9] A. B. Strong. Fundamentals of composites manufacturing: materials, methods and applications. *Society of manufacturing engineers*, USA, p. 5-6, 1989.
- [10] J. P. Cauchois. Processos em compósitos. In: ABMACO. *Compósitos I, materiais, processos, aplicações, desempenhos e tendências*. Sem editor, p.450-452,2009.
- [11] Standard Test Methods for Tensile Properties of Polymer Matrix Composite Materials. *American Society for Testing Materials*.
- [12] Leitão, E da Silva. Mechanical characterization of polymeric composites with the reinforcement at different orientations. IPEN-University of Sao Paulo, 2007.